

Li/Li_{1+x}V₃O₈ secondary button cells: dependence of cycle life on electrolyte nature and cycling regime

A. MOMCHILOV, V. MANEV, A. NASSALEVSKA

Central Laboratory of Electrochemical Power Sources, Bulgarian Academy of Sciences, Sofia 1040, Bulgaria

M. PASQUALI

Dipartimento I.C.M.M.P.M., Università di Roma-La Sapienza, Rome, Italy

G. PISTOIA*

Centro di Studio per la Elettrochimica e la Chimica Fisica delle Interfasi, C.N.R., Via Castro Laurenziano 7, 00161 Rome, Italy

Received 26 June 1989; revised 21 January 1990

The behaviour of the Li/Li_{1+x}V₃O₈ system in a secondary button cell has been investigated. It is shown that when using electrolytes based on LiAsF₆ (without stabilizing additives) the best results are achieved with cyclic esters. It is established that the charging conditions influence significantly the cell cyclability, while the discharge conditions have a limited effect. It is also demonstrated that mixtures of ethylene and propylene carbonate lead to a considerably better reversibility of the system. A satisfactory electrode performance has been obtained: 180 Ah kg⁻¹ at the 100th cycle for the positive electrode material and over 95% utilization of the Li electrode.

1. Introduction

The properties of the lithium vanadium bronze Li_{1+x}V₃O₈ have been the subject of a considerable number of studies. The results from the investigations of test and real electrodes at different current densities [1-4] have demonstrated the high specific energy of the material. This feature, along with the excellent electrode reversibility, makes this bronze one of the most promising materials for positive electrodes in secondary lithium cells.

All published studies on Li_{1+x}V₃O₈ have been performed in cells with a relative excess of electrolyte. In a real cell, however, the electrolyte is present only in the pores of the cathode and of the separator. The excess of electrolyte may considerably obscure the effects of all electrolyte decomposition phenomena, both homogeneous and heterogeneous [5].

The latter class includes all reactions involving solutions and electrodes. To the well known Li passivation due to solution reduction, one has to add the catalytic decomposition of the solution at the positive electrode surface, which can cause remarkable consumption of electrolyte during cycling of a real cell. These effects manifest themselves in a continuous increase of the internal resistance and in a reduction of the real cell capacity with cycle number. Obviously, degradation of the electrolyte at the positive electrode depends on the maximum potential value set for the charge. For a system with a mean discharge voltage of

2.6 V as Li/Li_{1+x}V₃O₈ [1], these effects will be more evident than for Li/MoS₂ cells with 1.8 V [6] and Li/TiS₂ cells [7, 8] with 2.2 V as a mean discharge voltage.

Homogeneous electrolyte decomposition [5], in other words the spontaneous processes occurring independently of the electrochemical reactions, also lead to a compositional change of the initial electrolyte.

All these phenomena are obviously of greater importance in starved cells. Indeed, in this case, the percentage of decomposed electrolyte with respect to the total amount will be much larger.

It follows that an excellent electrode performance in a test cell is a necessary, but not sufficient, condition for a satisfactory behaviour in a real cell. It can also be concluded that only tests of real cells can provide the correct answer as to the compatibility of the various positive electrodes with the various solutions proposed in recent years.

One of the most widely studied electrolytes, which certainly contributes to the excellent results obtained with the cells produced by Moli Energy, the leading manufacturer of commercial secondary Li batteries, is LiAsF₆ dissolved in a mixture of ethylene carbonate (EC) and propylene carbonate (PC) [6]. The satisfactory performance of this electrolyte in the Li/MoS₂ cells makes it a prospective target of investigation in connection with the considerably energy-richer Li/Li_{1+x}V₃O₈ system. In this work, the investigation has been carried out under the conditions of a real

* To whom correspondence should be addressed.

secondary button cell. In all tests with this and other solutions, no additives increasing the Li electrode efficiency have been used — this will be the subject of a following study.

2. Experimental details

All studies were carried out in the button cell shown schematically in Fig. 1. The Li anode was a 0.2 mm thick lithium foil pressed onto an expanded Ni grid. Each cell was fitted with two layers of a microporous polypropylene separator (Celgard 2400 produced by Celanese Corp.). Preliminary tests had shown that with one layer of separator the possibility of lithium dendrite penetration sharply increased after the 150th cycle. With solvents of the cyclic esters group, the separators were impregnated using a proprietary technique [9, 10].

The cathode was a 7:3 mixture of $\text{Li}_{1+x}\text{V}_3\text{O}_8$ (particle size, 1–5 μm) and Teflonized carbon black, pressed on a Ni grid at 10 ton cm^{-2} and sintered at 340°C for 5 min. The conditions for the synthesis of the bronze have already been described [3, 4]. Teflonized carbon black, with a Teflon to carbon ratio of 1:2, was obtained by carefully blending the two components dispersed in a slurry. The amount of cathodic active material was 15 mg cm^{-2} . Electrochemical grade LiAsF_6 , received from USS Agri-Chemicals, was dried for 96 h under vacuum at 80°C.

Dimethoxyethane (DME), tetrahydrofuran (THF), 2-methyltetrahydrofuran (2MeTHF) and methyl formate (from Aldrich) were purified as already described [1–3]. PC, distilled-in-glass grade (from Fluka), was used as received. EC (also from Fluka) was subjected to additional vacuum distillation. The moisture level of the electrolytes was below 20 ppm, as checked with a Mitsubishi moisturemeter, model CA-02.

The assembling of the cells was carried out in an argon-filled glove box with automated maintenance of the moisture content below 10 ppm. The cells were assembled after preliminary impregnation of cathode and separator with electrolyte without adding an extra amount in the cell.

Cycling experiments were performed under galvanostatic conditions with charge and discharge cut-off of 3.2 and 1.8 V, respectively. The charge voltage cut-off was raised to 3.5 V in the special test of its effect on the cell cyclability. The cell resistance was measured at 1 kHz with an RC-bridge. It is possible that this resistance does not coincide with that obtainable by extrapolating to the real axis impedance values measured at various frequencies.

static conditions with charge and discharge cut-off of 3.2 and 1.8 V, respectively. The charge voltage cut-off was raised to 3.5 V in the special test of its effect on the cell cyclability. The cell resistance was measured at 1 kHz with an RC-bridge. It is possible that this resistance does not coincide with that obtainable by extrapolating to the real axis impedance values measured at various frequencies.

3. Results and discussion

The choice of solvents from the cyclic esters group, such as PC and EC, was made after a series of preliminary studies. Some of the results obtained are given in Fig. 2. This figure shows the dependence of cell capacity on cycle number using different electrolyte solutions based on LiAsF_6 . The charge and discharge current density for all experiments was 1 mA cm^{-2} . Cycling was discontinued when the cell capacity reached 50% of the initial value.

From the curves presented in Fig. 2 it can be concluded that in solutions not containing any additives, the best results are obtained with pure PC. This conclusion is confirmed by the cell resistance measurements at the end of the charge. Fig. 3 shows the resistance of some cells as a function of cycle number. It can be seen that at the beginning of cycling the increase of the cell resistance for solutions containing THF + 2MeTHF and PC + MF is much faster than for those containing PC or PC + DME. The rapid resistance rise is an indication of the reactions of these solvents at the negative and at the positive electrodes.

While the cell capacity continuously decreases with all other solvents (Fig. 2), a flat maximum can be observed with PC. This maximum cannot be explained by the decrease of the internal resistance. As shown in Fig. 3, the cell resistance between the 30th and the 90th cycle displays a monotonic rise, while in the same interval the cell capacity increases. A possible

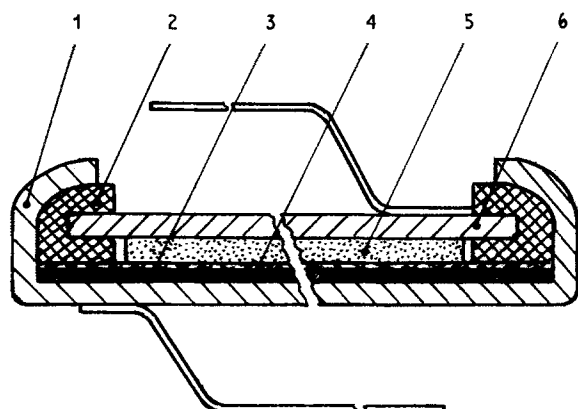

Fig. 1. Schematic diagram of the button cell: 1 — can, 2 — gasket, 3 — lithium anode, 4 — separator, 5 — cathode, 6 — lid.

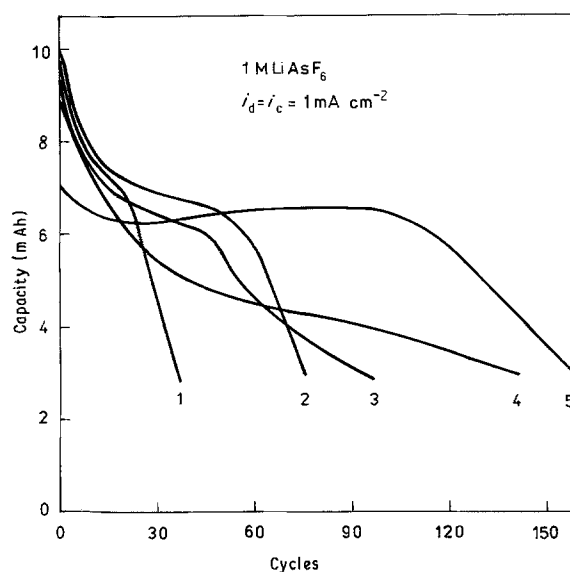

Fig. 2. Influence of the type of solvent on the cycle life: 1 — PC:DME, 2 — THF:2MeTHF, 3 — 2MeTHF, 4 — PC:MF, 5 — PC. In all solvent mixtures the ratio is 1:1.

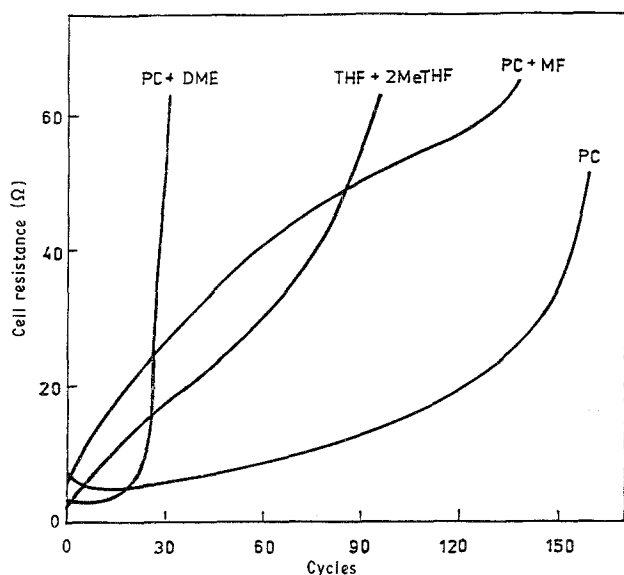

Fig. 3. Effect of the cycle number on the cell resistance at 1 kHz for different solutions containing 1 M LiAsF₆.

explanation may be that the lithium dendrites formed have a larger volume than bulk Li, thus decreasing the contact resistances between electrodes and separator-solution. This positive effect is masked in all other solutions by the prevailing negative effects.

On the basis of the results shown in Figs 2 and 3, further investigations were only performed with electrolytes containing solvents of the cyclic esters group. Typical charge-discharge curves of cells with 1 M LiAsF₆, at the charge and discharge current density of 1 mA cm⁻², are presented in Fig. 4a, while Fig. 4b displays the corresponding values of the cell resistance. It can be seen that substantial resistance changes take place throughout a full cycle. This can be explained by the variation of the electrode volume occurring in the course of one cycle. During discharge, Li dissolves forming free space which is difficult to compensate in spite of the probable redistribution of the electrolyte. During charge, Li is restored and the resistance decreases to its initial value. With the

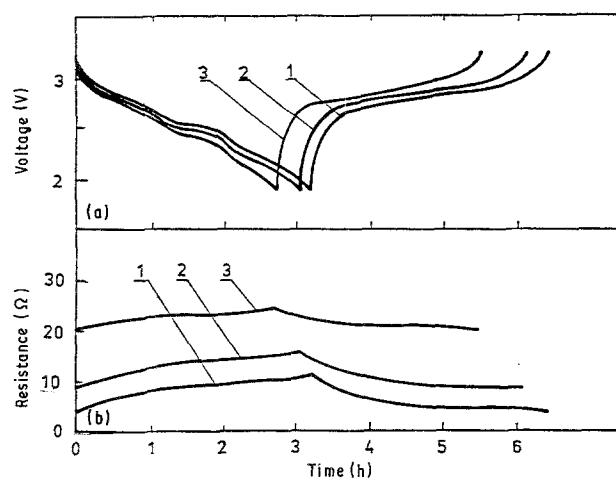

Fig. 4. (a) Typical charge-discharge curves of cells containing 1 M LiAsF₆ in PC at the (1) 5th, (2) 50th and (3) 120th cycle. (b) Their corresponding resistances measured at a frequency of 1 kHz.

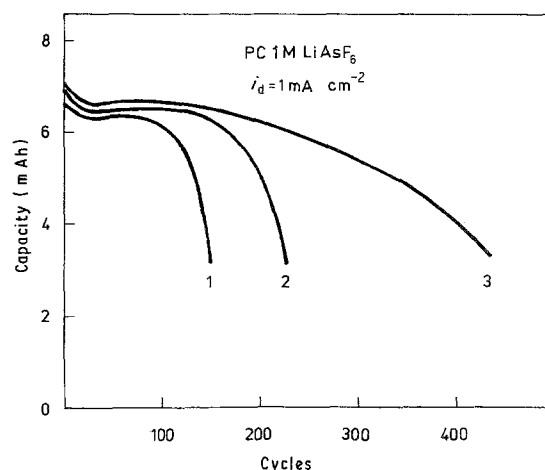

Fig. 5. Effect of the charge conditions on the cycle life of cells containing 1 M LiAsF₆ in PC at a discharge current density of 1 mA cm⁻². The charge current density is: (1) 1 mA cm⁻², (2) 0.5 mA cm⁻² and (3) 0.25 mA cm⁻².

increase of the cycle number, Li dendrites are formed which increase the overall cell resistance and considerably obscure the effect of the volume reduction.

Figure 5 illustrates the cycling behaviour of a cell containing 1 M LiAsF₆ in PC, as a function of the charging conditions. The figure demonstrates the significant influence of the charge current density on the cycling capability. When the charge current density is reduced from 1 to 0.25 mA cm⁻², the cycle number increases more than 2.5 times and the cell may sustain more than 400 cycles at high DOD.

The partial substitution of PC with EC in the electrolyte also improves the cell cyclability. Figure 6 shows that substitution of half of the PC volume with EC increases the cycle number by 50%, while at the PC : EC ratio of 1 : 3 the number of cycles increases by 70%. As can be seen in Fig. 6, this substitution also leads to an increase of the cell capacity.

The strong influence of the charge rate (Fig. 5) on the cell cyclability led us to suppose that it might also be affected by the discharge rate. Figure 7 shows that an increase in the discharge current density even

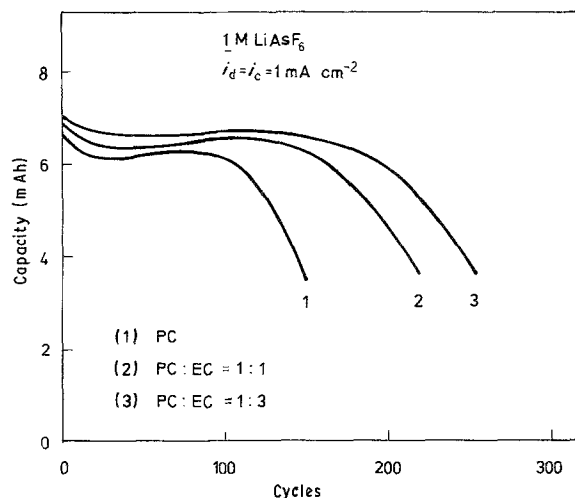

Fig. 6. Effect of the PC : EC ratio in the electrolyte on the cell cycle life at $i_d = i_c = 1 \text{ mA cm}^{-2}$.

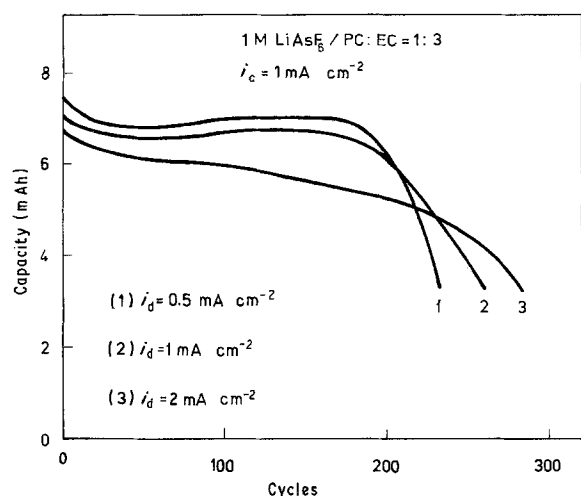

Fig. 7. Effect of the discharge rate on the cycle life of cells with electrolyte 1 M LiAsF₆ in PC: EC (1:3). The charge current density is 1 mA cm⁻² and the discharge current density is: (1) 0.5 mA cm⁻², (2) 1 mA cm⁻² and (3) 2 mA cm⁻².

causes a slight increase of the cycle number because of the lower DOD. Integrating the curves of Fig. 7, it can be seen that by decreasing the discharge current density the total capacity increases slightly. It can be concluded that the influence of the discharge current on the cell cyclability is marginal within certain limits.

All results shown so far have been obtained with a 3.2 V cut-off for the charge. The upper voltage limit may influence the cycle life. Figure 8 shows the effect of the increase of this limit from 3.2 to 3.5 V in two cases: with pure PC and with PC + EC. It can be seen that, with pure PC, raising the voltage limit decreases the cyclability by about 20%, while with a mixture of PC and EC (1:3) the change is less significant.

The dependencies presented in Figs 4–8 show a very good compatibility between Li_{1+x}V₃O₈ and electrolytes based on LiAsF₆ dissolved in the cyclic esters. Furthermore, it has to be taken into account that after a 50% capacity loss, post-mortem check-up of the cells showed that their cycle life has been entirely determined by the Li electrode. This conclusion was confirmed by the fact that the cathodes, transferred to other cells, were capable of delivering many cycles with nearly their initial capacity.

The best cathode performance was obtained when using a 1:3 PC + EC mixture. Indeed, with this ratio, the specific capacity of the positive electrode

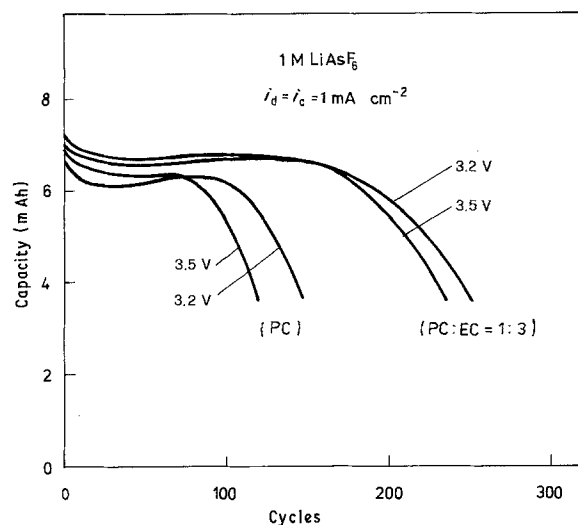

Fig. 8. Effect of the change of the charge voltage limit on the cycle life.

active material has an exceptionally high value – 180 Ah kg⁻¹ at the 100th cycle.

The performance of the lithium electrode is shown in Tables 1 and 2. Table 1 presents the cycle number, the Li utilization and the related figure of merit (FOM) [11], as a function of the type of solution. Table 2 gives the values of the same parameters as a function of the charge current density. The best utilization, at 0.25 mA cm⁻², is > 95% and the FOM is > 20, which is obviously a good achievement. If, however, we take into account that this was obtained with pure PC, using PC + EC is expected to further increase the Li utilization.

4. Conclusion

The possibility of using Li_{1+x}V₃O₈ in practical rechargeable Li cells has been demonstrated. This material can sustain several hundreds of deep cycles provided that a judicious choice of the electrolyte is made. Furthermore, the capacity and energy outputs remain fairly high under optimized conditions. As an example, at the 100th cycle in LiAsF₆ – PC + EC, 180 Ah kg⁻¹ may still be obtained. This corresponds to an energy density, calculated on the cathode weight (additives included), of 327 Wh kg⁻¹. This figure allows the forecast that the goal of 100 Wh kg⁻¹ may be reached in real cells, while the power density should also have interesting values on account of the rate capability of the system.

Table 1. Influence of the PC: EC ratio on the performance of the Li electrode

Solvent	Number of cycles	FOM	Utilization (%)
PC	150	8.94	88.8
PC + EC = 1:1	210	10.57	90.54
PC + EC = 1:3	255	12.4	91.93

Table 2. Influence of the charge current density on the performance of the Li electrode in 1 M LiAsF₆-PC

Current density (mA cm ⁻²)	Number of cycles	FOM	Utilization (%)
0.25	430	22.1	95.48
0.5	230	12.1	91.73
1.0	150	8.94	88.82

References

- [1] G. Pistoia, S. Panero, M. Tocci, R. Moshtev and V. Manev, *Solid State Ionics* **13** (1984) 311.
- [2] G. Pistoia, M. Pasquali, M. Tocci, R. Moshtev and V. Manev, *J. Electrochem. Soc.* **132** (1985) 281.
- [3] M. Pasquali, G. Pistoia, V. Manev and R. Moshtev, *ibid.* **133** (1986) 2454.
- [4] G. Pistoia, M. Pasquali, Y. Geronov, V. Manev and R. Moshtev, *J. Power Sources* **27** (1989) 35.
- [5] V. Koch, The Second International Rechargeable Battery Seminar, Deerfield Beach, Florida, USA (1988) p. 238.
- [6] J. Stiles, in 'Practical Lithium Batteries' (edited by Y. Matsuda and C. R. Schlaikjer), JEC Press, Cleveland, Ohio, USA (1988) p. 74.
- [7] K. Abraham, L. Goldman and F. Martin, in Proc. 31st Power Sources Symp., The Electrochemical Society (1984) p. 98.
- [8] M. Anderman, J. Lundquist, S. Johnson and R. Giovannoni, Proc. 4th Int. Meeting on Lithium Batteries, Vancouver, Canada, May (1988) p. 90.
- [9] V. Manev, A. Nassalevska and A. Momchilov, Bulg. Pat. No. 80 434 (1987).
- [10] V. Manev *et al.*, to be published.
- [11] K. M. Abraham, J. L. Goldman and D. L. Natwig, *J. Electrochem. Soc.* **129** (1982) 2404.